



**National Vocational
Qualification Framework
version 2**

NVQF

To deliver a skilled and qualified workforce in Pakistan

Version 2

October 2017

National Vocational and Technical Training Commission



National Vocational Qualification Framework

Version 2

October 2017



TABLE OF CONTENTS

Abbreviations	I
Preface	III
Message from Federal Minister for Education & Professional Training	V
Executive Summary	VII
Introduction	01
Structure of NVQF	02
Development of NVQs	03
Development of Competency Standards	03
Categorization and Leveling Competency Standards	04
Review of NVQs	04
Coding of NVQs	04
Development of Competency Based Curriculum	05
Crediting NVQ	05
Development of Trainers and Learner's Guides	06
Assessment of NVQs	07
Development of Assessment Guides	07
Training and Certification of Assessors	08
Accreditation of QABs and Assessment Centers	08
Conduct of Assessment	08
Certification of NVQs and Record Keeping	09
Re-assessment and Appeals against Assessment	09
Moderation of Assessment	09
Recognition of Prior Learning (RPL)	09
Management of NVQF	11
Management Structure	11
Managing NVQs Equivalences	12
Monitoring and Evaluation of NVQs	13
Managing NVQF Review and Improvement	14
Managing NVQ Registry	14
Quality Assurance	16
Quality assurance of NVQF qualifications	16
Quality assurance of the delivery and conduct of training	16
Quality assurance of assessment	17
Quality assurance of the management	17
Monitoring and Evaluation	17
Provisions of Foreign Qualifications in Pakistan	18
Relationship with International NVQs	19
Appendices	20
Appendix-1: NVQF Level Descriptors	20
Glossary	21



ABBREVIATIONS

B. Tech	Bachelor of Technology
CBT	Competency Based Training
CCDTE	Committee of Chairmen and Directors of Technical Education
CSs	Competency Standards
CUs	Competency Units
DAE	Diploma of Associate Engineer
EQF	European Qualification Framework
HEC	Higher Education Commission
IBCC	Inter Board Committee of Chairmen
LOs	Learning Outcomes
M&E	Monitoring & Evaluation
M. Tech	Master of Technology
NAVTTTC	National Vocational and Technical Training Commission
NMC	NVQF Management Committee
NSIS	National Skill Information System
NSS	National Skill Strategy
NSUs	NVQF Support Units
NVC	National Vocational Certificate
NVQs	National Vocational Qualifications
NVQF	National Vocational Qualifications Framework
PVTC	Punjab Vocational Training Council
QA	Quality Assurance
QABs	Qualification Awarding Bodies
QDC	Qualification Development Committee
RPL	Recognition of Prior Learning
TEVTAs	Technical Education and Vocational Training Authorities
ToRs	Terms of References
SSC	Sector Skills Councils
TLM	Teaching and Learning Material
TVET-SSP	TVET Sector Support Programme
UAE	United Arab Emirates
VET	Vocational Education & Training



PREFACE

Pakistan's first National Vocational Qualification Framework (NVQF) was launched in March 2015 after series of consultations with all TVET stakeholders. It facilitated in introducing competency-based courses in TVET institutions, which were developed by NAVTTC under the TVET Sector Support Program (SSP) in collaboration with European Union, the Embassy of the Kingdom of Netherlands, the Federal Republic of Germany and the Royal Norwegian Embassy. The program was commissioned by the German Federal Ministry for Economic Cooperation and Development (BMZ) and was implemented by Deutsche Gesellschaft für Internationale Zusammenarbeit (GIZ) GmbH in close collaboration with NAVTTC.

The two years pilot and experimental introduction of National Vocational Qualifications (NVQs) across the country gathered lots of experience and feedback from TVET service providers and institutions which brought forward the need to revise the main NVQF document and its support manuals so as to further streamline the procedures and processes for development, assessment and management of NVQs. In a joint workshop of all stakeholders in November 2016, it was decided to review the existing 11 operational manuals and merge them in to 3 operational manuals each on, "Development of NVQs", "Assessment of NVQs" and "Management of NVQs" and also revise the main NVQF document.

The second phase of TVET SSP plans for development of new NVQs and also review already developed qualification so as to comprehensively package them from level 1 to 4. It also includes human resource development component to develop capacity of management and assessment bodies and training institutions and thus preparing them to efficiently and smoothly implement NVQs.

The main document of NVQF and its supported operational manuals will remain a dynamic document and procedures and processes prescribed in the revised operational manuals will be kept updated upon input and suggestions received from the TVET service providers.

Zulfiqar Ahmad Cheema

Executive Director

NAVTTC, Islamabad

Islamabad September 2017

MESSAGE FROM FEDERAL MINISTER FOR EDUCATION & PROFESSIONAL TRAINING

Pakistan is blessed with a tremendous human resource potential where around 60% of the population is below 30 years of age. This energetic youth is available for employable skills under a credible, reliable and internationally recognized TVET system for converting them into a demographic dividend for Pakistan's economy.

The present era marks resurgence of TVET in Pakistan. Several reform-based initiatives are being taken for development of the technical and vocational education system, in collaboration with private sector participation and with technical assistance of our valued development partners from the international community. One of the important components of these reforms has been the development and implementation of this National Vocational Qualifications Framework, which aims at bringing a paradigm shift by making TVET delivery credible, marketable and consistent with international demands.

I am pleased to present this outcome of an extensive consultation process with all TVET stakeholders in the form of the second version of the Pakistan National Vocational Qualification Framework (NVQF) supported with three operational manuals. I am sure these will help in the establishment of a coherent national system of TVET qualifications, promote demand-based training through an efficient assessment mechanism and lead to improvement in the overall quality of TVET in conformity with the National Skill Strategy and in pursuance of the National TVET Policy.

Muhammad Baligh Ur Rehman

Minister for Federal Education
and Professional Training
Islamabad

EXECUTIVE SUMMARY

This framework is an overarching document, which is supported with three operational manuals; Manual 1 on “Development of NVQs”, Manual 2 on “Assessment of NVQs” and Manual 3 on “Management of NVQs”. Each manual describes in detail, procedures and processes in development of NVQs, in conduct of NVQs assessment and in management of NVQs. This main NVQF document consists of five sections on which policy guidelines have been given for efficient and smooth development, assessment and management of National Vocational Qualifications.

Structure of NVQs

The revised NVQF contains levels 1 to 8 qualifications with levels 1 to 4 for National Vocation Certificates, Level 5 for Diploma and Level 6 to 8 leading to graduate and post graduate level degree qualifications assuring the upward mobility within TVET sector. NVQs certification for level 1 to 5 falls within the purview of the Qualification Awarding Bodies (QABs) while certification of qualifications for level 6 to 8 falls within the purview of universities. Each level of the qualification is defined by a set of approved Level Descriptors, describing the broad outcomes expected of achievers and the complexity of skills and knowledge at that level.

Development of NVQs

NVQs will be developed in response to demands of the labour market and national priorities with involvement of academia and industry at key stages in the development process. The procedures and processes thus involve development of competency standards derived from the DACUM or Functional Analysis approaches with participation of industry experts, development of assessment evidence guides for each single competency standard as well as for integrated assessment in collaboration and development of competency-based curriculum with participation of both industry and academia. It further specifies the procedure for registration and notification of NVQs under the NVQF system.

Assessment of NVQs

NVQs assessment will be conducted through a well-defined system of assessment. The procedures and processes involved are training of sufficient and competent assessors, ensuring minimum essential standards for quality assurance through accreditation of Qualification Awarding Bodies and the Assessment Centers and providing pathways for formal, non-formal and informal candidates' entry and to gain NVQs certification after passing through the integrated assessment. It also facilitates students to achieve either a full qualification or a record of achievement if he/she doesn't further want to pursue for full qualification. Procedures to keep record of successful candidates, a moderation system to ensure fair, valid and consistent assessment across the country and an opportunity for appeals and re-assessment have also been described.

Management of NVQs

NVQF management system has been made efficient, effective and smooth with prescribing a well-defined management structure at the national and provincial levels with clear role and responsibilities of management bodies. NVQF support units (NSUs) established by the management bodies will manage implementation of NVQF at the national and provincial levels. An “NVQF Management Committee” (NMC) has been constituted at the national level to overall manage and give policy directions on management and implementation of NVQs.

Quality Assurance of NVQs

The NVQF Quality Assurance (QA) system consists of five major interrelated and interconnected systems;

- a) Quality assurance of NVQF qualifications
- b) Quality assurance of the delivery and conduct of training
- c) Quality assurance of assessment and certification
- d) Quality assurance of the NVQF management system and
- e) Monitoring and evaluation of the NVQF.

The three NVQF support manuals cover all these 5 quality aspects.

INTRODUCTION

The second version of National Vocational Qualifications Framework (NVQF) has been developed on the basis of experience gained and feedback received from TVET service providers and individual TVET experts from the academia and industry after implementation of NVQs in selected TVET institutions throughout the country. The revised NVQF version 2 is thus more aligned with the functions, roles and responsibilities of TVET service providers at the national and provincial levels. This NVQF document is supported with the three operational manuals; Manual-1 on Development of NVQs, Manual-2 on Assessment of NVQs and Manual-3 on Management of NVQs, which describe guidelines and procedures on each aspect.

This NVQF document describes NVQF levels and level descriptors and brief description of procedures and policy guidelines for development, assessment and management of NVQs.

The Chapter on “Development of NVQs” provides policy guidelines, procedures and processes for development of qualification and registration under the NVQF system. Each qualification will have a specific date of review and hence criteria and procedure for review of the qualification has also been prescribed. Detail is given in the Manual-1 on “Development of NVQs”.

The Chapter on “Assessment of NVQs” provides policy guidelines, procedures and processes for undertaking assessment of NVQs by the QABs and Assessment Centers including assessment for Recognition of Prior Learning (RPL). Moderation system to ensure fair, valid and consistent assessment and opportunity for appeal and re-assessment has also been prescribed. Detail is given in the Manual-2 on “Assessment of NVQs”.

The Chapter on “Management of NVQs” provides policy guidelines, procedures and processes for managing implementation of NVQs by the national and provincial TVET bodies in the public and private sectors. It also describe management of equivalences of NVQs at four areas; equivalences within NVQs, Equivalence of NVQs with existing (traditional TVET qualifications, with qualification of general and higher education and equivalence with foreign qualifications. Detail is given in Manual-3 on “Management of NVQs”.

Glossary has been added to understand the terms used in this document.

STRUCTURE OF NVQF

The revised structure of NVQF contains eight levels. National Vocational Certificates for level 1 to 4 and Diploma for Level 5 will be assessed and certified by QABs and graduate and postgraduate qualifications i.e. Level 6 to 8 will be assessed and degrees awarded by universities accredited by HEC. The Figure 1 below shows structure of the NVQF.



Figure 1: The National Vocational Qualification Structure
The present version of NVQF is covering levels 1 to 4 only. Qualifications from level 5 to 8 will evolve gradually.

Each Level of the qualification framework is defined by a set of approved level descriptors (Appendix 1). They describe the broad outcomes expected of pass-outs under three categories of "Knowledge & Understanding", "Skills" and "Responsibilities". The level descriptors are used as guidelines for levelling competency standards, development of assessment guides, curricula and trainers and learner's guides.

The National Vocational Certificate (NVC) level 1 to 4 prepares students from a semi-skilled person to a professional who possess necessary knowledge of an area of work or study from elementary to comprehensive knowledge as per level requirements, skills required to carry out and complete the tasks as per level complexity and take the responsibility from limited supervision (level 1) to full autonomy (level 4). The Diploma (Level 5) prepares students to become specialist having advanced theoretical knowledge of an area of work or study, possess mental, technical and practical skills to complete tasks, carry out planning and development with complete accountability.

DEVELOPMENT OF NVQs

The process for development of a new National Vocational Qualification (NVQ) shall start with undertaking a labour market demand analysis, which shall provide justification and rationale for development of the qualification. A Qualification Development Committee (QDC) shall then be constituted in consultations and approval with NAVTTC and respective TEVTAs to develop and finalize the Competency Standards (CS) and Assessment Evidence Guides for that qualification. The Figure-1 below shows processes for development and finalization of competency standards and assessment evidence guides for a new national vocational qualification.

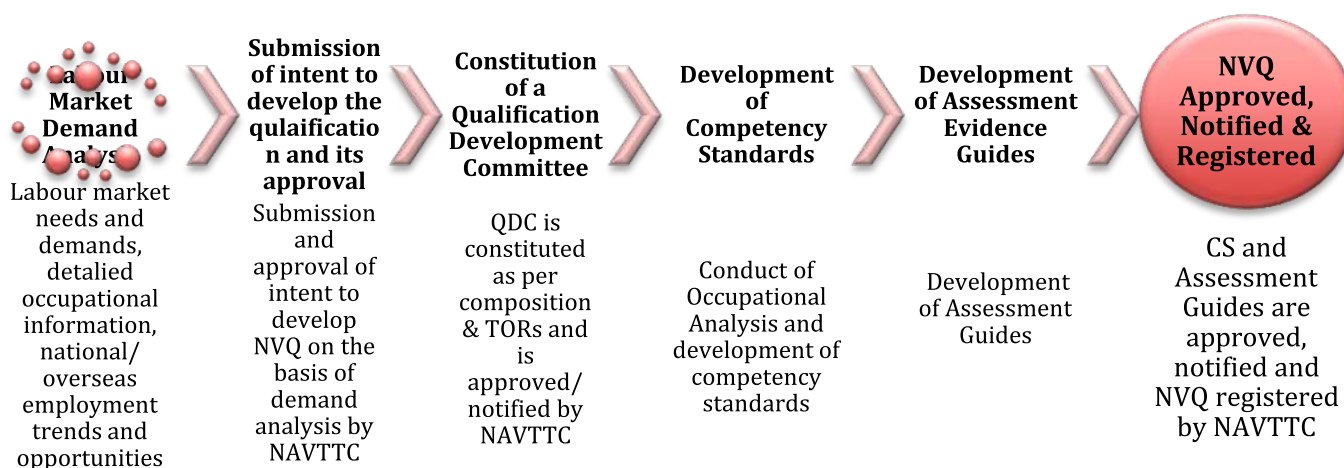

Figure 2: Process for development of NVQ

Competency Standards approved and notified will make the NVQ eligible for its registration in the NVQ Registry System.

All NVQs will be levelled as per NVQF level descriptors and thus each NVQ will have competency standards (generic, functional and technical) from level 1 to 5. A qualification summary sheet shall also be developed that will provide necessary detail e.g. title, level, date of development, version number, time in credit hours, competency standards, code and other requirements.

Development of Competency Standards

NVQs shall be developed on the basis of skill demand analysis using the labour market information system, labour force survey and statistics of skilled workforce yearly published by the Government of Pakistan. It will be based on evidence of support from relevant industry and sector skills councils. Public and private sector TVET service providers will submit their intent to NAVTTC to develop NVQs according to the laid down procedures and processes described in the Manual-1 on “Development of NVQs”.

NAVTTC shall verify the rationale/skill demand analysis and documents provided and will give go-ahead to develop the qualification or may indicate missing information/documents.

Once the intent to develop the NVQ is cleared by NAVTTC, the NAVTTC will constitute a Qualification Development Committee (QDC) in consultation with industry and applicant, which will be approved and notified by NAVTTC. The composition and terms of reference of QDC are given below.

Composition of QDC

- Representative from NAVTTC
- Six members with wide experience in occupations within the industry sector who are current practitioners (nominated by industry, SSC, CCI, Trade Associations etc.)
- Six representatives from private and public training providers (from TEVTAs, PVTC, QABs, and private training institutions as appropriate)
- A Certified CBT Assessor of the same sector (Allied sector)

Terms of Reference of QDC

- Identify and nominate Occupational Analysis Panel and a Facilitators for occupational profiling
- Conduct workshops and finalize the chart (s)
- Identify suitable practitioners to take part in competency standards development and the development of assessment guides
- Conduct competency standards and assessment guides development workshops.
- Undertake industry validation of competency standards and assessment guides and finalize documents for submission and notification of NAVTTC

The Qualification Development Committee (QDC) will be responsible for occupational profiling. Since it involves high-performing incumbent workers to analyse their own job and identify the duties & tasks that make up their jobs, the QDC will constitute a panel, appoint a competent facilitator, and get an occupational profile prepared in a chart format, which describes various levels of an occupation in terms of specific jobs, duties and tasks that competent workers must perform.

The QDC on the basis of occupational profiling chart will develop and finalize Competency Standards (CSs) and Competency Units (CUs) on the basis of major duties and tasks listed in the chart and develop the full package of the competency standard document including performance criteria, underpinning knowledge and understanding, level, requirements for progress and achievement, pathways, equivalences and other conditions.

The competency standards developed shall be validated by the relevant industries/Sector Skills Councils to confirm the accuracy of the competency standards and get their feedback and endorsement.

Categorization and Levelling Competency Standards

All competency standards in the NVQ shall be categorized in to "Generic", "Functional" and "Technical" and be levelled according to NVQF level descriptors. Each qualification shall include competency standards for level 1 to 4.

Review of NVQs

Review of NVQs

QDC/NAVTTC shall assign a review date to each qualification to ensure its relevance validity. The review date shall be three-years from the date of industry validation, but in areas where technologies are advancing rapidly or where major changes are expected it can also be less than 3 years.

Coding of NVQs

Coding of NVQs

Each NVQ and its competency standards shall be assigned unique codes by the National Vocational Registry System as a national vocational qualification identifier. This shall be based on International Standards of Classification of Education (ISCED).

The NVQ once approved by NAVTTC will be registered and notified for information of all stakeholders.

DEVELOPMENT OF COMPETENCY BASED CURRICULUM

Competency-based curriculum shall provide overall course guidelines in relation to teaching and learning and act as the key instrument in supporting standardized formal, non-formal and informal training. Curriculum development thus aims at providing a bridge between competency standards and actual delivery of the training/teaching program and hence is an important source in the development of trainers and learner's guides.

NAVTC or TEVTAs or any other agency may constitute a Curriculum Development Committee (CDC) with the following composition and TORs (optional).

Composition of CDC

- Representative of NAVTC
- Industry representatives/ SSCs
- Experts from private and public training providers
- Instructors from TVET institutions with experience, knowledge and writing skills from the relevant sector
- Certified CBT Assessor of the same sector (Allied sector)

Terms of Reference of CDC

- Examine the qualification, competency standards and level to identify requirements for curriculum
- Devise the curriculum that will support the achievement of the competency standards and the qualification
- Define the credit value of the qualification after assigning credit value to each learning unit.
- Provide supportive notes on trainers and learner's guides' writers, assessment context, critical aspects, assessment conditions and resources required for assessment.
- Ensure industry validation of the curriculum.

Crediting NVQ

The credit value of the whole qualification shall defined by estimating the amount of time/instruction hours required to complete each competency unit and competency standard. The NVQF uses a standard credit value of 1 credit = 10 hours of learning (following Higher Education Commission (HEC) guidelines). For example:

Table 1: Assigning Credit Value to the Competency Standards

Competency Standards	Estimate of hours	Credit
Identify Design Tools	100	10
Conceive a Design Concept	200	20
Analyse Cost Effective Solutions	100	10
Edit Photos and Development of Graphics	50	5
Prepare Pre-Press Job	200	20
Perform basic Hardware Maintenance	200	20
Communicate with Others	100	10
Describe rights at the workplace	50	5
	1000	100

The CDC shall finalize the curriculum on the basis of industry feedback and submits it to NAVTC for approval, notification and uploading on the website for information

DEVELOPMENT OF TRAINERS AND LEARNER'S GUIDES

The Qualification Development Committee (QDC) may assign for development of Trainers and Learner's guides to any relevant institution/ organization/group of professional writers/individual (s) through a contract giving them a fixed timeline.

Once the draft Trainers and Learner's Guides are developed, the CDC in consultations with NAVTTC and TEVTAs shall constitute a T&L guides review committee with the following composition and TORs.

Composition

- Subject matter experts
- Trainers and instructors from the training institutions who possess relevant academic background and teaching experience
- 2-3 industry representatives for that trade,

Terms of Reference

The T&L guides review committee will check that guides don't have spelling, grammatical and technical mistakes and ensure:

- The compliance of T&L with CBT Curriculum
- T&L supports the Learning Outcomes of the curriculum
- That the images used are proper and legally allowed
- Learning activities are aligned with learning outcomes
- Learning activities reflect the performance criteria/ skills identified in the competency standards
- Learning activities support the knowledge & understanding specified against those skills
- That the trainees have adequate time to practice or apply the desired learning
- That it facilitates in getting/providing feedback on the T&L guides

ASSESSMENT OF NVQS

Assessment is the key to achieve the NVQF qualification through whatever the pathway an individual is coming from. A comprehensive assessment system shall be designed that caters for the needs of all individuals whether they are coming from formal system or informal/non-formal systems. The three main objectives of NVQs assessment system shall be to:

- Provide evidence that the candidate is capable of performing the competencies being assessed according to the national competency standards through whichever the pathway an individual is coming from;
- Assure that assessment is fair, valid and consistent across the board; and
- Issue a national certificate of vocational qualification or record of achievement to individuals declared "Competent" for a full/ complete qualification or in certain numbers of competency standards, respectively.

NVQs assessments are conducted to assess candidate's skills, knowledge and attitudes against set industry standards through various modes such as demonstrations, simulations, presentations, assignments, projects, creations, and scenarios. The Figure 4 shows different pathways that individuals may take to acquire a national vocational qualification.

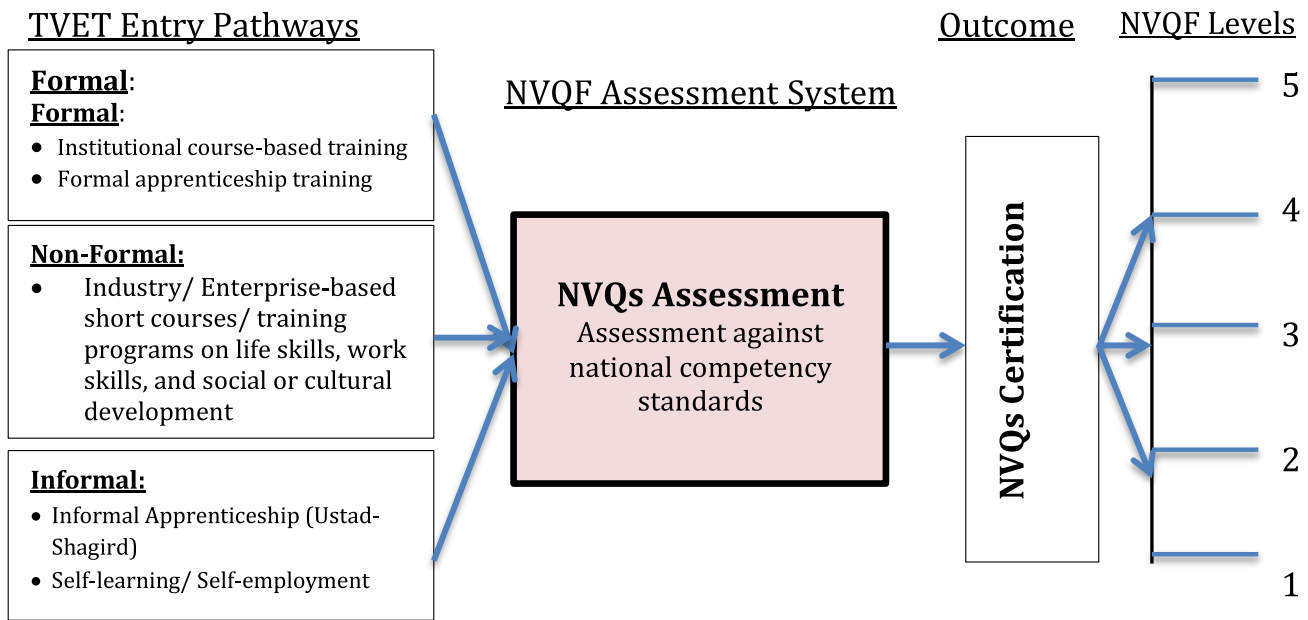

Figure 3: Pathways to achieve NVQ

Development of Assessment Guides

The process for development of assessment evidence guides shall include:

- Development of the assessment package based on the competency standards by the Qualification Development Committee (QDC) in line with national templates and guidelines provided in the Manual-1 on "Development of NVQs".
- Review of assessment guides by NAVTTC to ensure that they are consistent with prescribed knowledge and

understanding, specific skills and performance criteria described against each competency standard. Validate the assessment guides after gaps & deficiencies, if found, are removed.

- c) Notification of the assessment guides and uploading it on the NAVTTC website for use by QABs/ Assessment Centers/ Assessors.

Training and Certification of Assessors

Only certified competency assessors registered with NAVTTC can conduct NVQ assessment. The process for training, certification and registration of assessors is given below:

- a) Three categories of assessors will be trained, certified and registered;
 - Certified Assessor (Level 2) authorized to conduct assessment
 - Advanced Assessors (Level 3) authorized to conduct NVQs assessments and design assessment material
 - Lead/Master Assessors (Level 4) authorized to conduct NVQs assessment, conduct Assessor's training, coaching and mentoring

Criteria for selection of instructors and trades experts from the industry to select and train the assessors under the above-mentioned categories have been described in the NVQF operational manual 2 on "Assessment of NVQs". Training of assessors will be done by QABs and the Assessment Centers. NAVTTC will register the certified assessors in NVQ Registry system.

Accreditation of QABs and Assessment Centers

In order to ensure quality of assessment of NVQs, the Qualification Awarding bodies, the assessment centres and the TVET institutions offering NVQs, shall be accredited according to the nationally agreed criteria, guidelines and processes. The accreditation will be conducted at the following three levels.

- a) Accreditation of Qualification Awarding Bodies by NAVTTC
- b) Accreditation of Assessment Centers by QABs
- c) Accreditation of TVET institutions/programmes offering NVQs by NAVTTC

Separate manuals on accreditation describe the procedures and processes for accreditation at the all above-mentioned three levels.

The public and private sectors training institutes and industrial units having training facilities, requisite equipment and materials will approach respective QABs for accreditation as NVQs assessment centres.

Conduct of Assessment

The assessment centres shall ensure availability of all necessary pre-requisites prior to the conduct of final assessment by the certified assessors appointed by the respective QABs. It will involve preparation of information of trainees who have completed all the requirements for integrated assessment. The detail is given in the Manual-2 on "Assessment of NVQs".

QABs will prepare schedule of assessment and disseminate it to all concerned institutes. Number or panel of assessors will be determined according to the number of candidates and it will be dependent upon the type of trade being assessed and facilities available. To ensure industry involvement, relevant technical representative from the specific industry will be assigned as an observer in the assessment panel.

The assessors will provide briefing/instructions to each candidate on assessment in accordance with assessment evidence guide, conduct assessment as per instructions given in the integrated assessment evidence guide and fully observe the professional code of conduct. They will also check folders of modular/ formative assessment in case some further information and evidence is needed during the integrated assessment. Finally, the assessors will summarize assessment and record final decision about the candidate as per format provided to them in the integrated assessment evidence guide.

The assessors will submit the result of the assessment to the respective QAB.

Certification of NVQs and Record Keeping

NAVTTTC as per its Act 2011 shall devise a system for award of NVQ certification to the successful candidates in collaboration with QABs.

The QABs and the Assessment Centers will follow the system devised by NAVTTTC and use only nationally agreed/approved NVQs certificate template for award of full qualifications and for award of record of achievement respectively.

The "Record of Achievement" will be issued by the assessment centres to those candidates who have been declared "Competent" in few competency standards during modular assessment done by the trained instructors and who don't want to continue further to pursue for full qualification.

Re-assessment and Appeals against Assessment

The candidates declared "Not-yet-Competent" would be informed by the assessors, that they can appear for re-assessment without participating in any further obligatory training. However, they may benefit from further training or practice before applying for re-assessment but re-assessment will not be restricted by a requirement of re-training.

Candidates may file an appeal against assessment along with evidence to the respective QAB.

Moderation of Assessment

The QABs will conduct moderation of assessment after an integrated assessment using assessment evidence guides. This post-assessment moderation shall ensure that the assessment that took place and the evidence collected on which the judgment was made, met the principles of moderation, the requirements of the competency standard and the expectations of the industry.

The principles of moderation will include checking and verifying that evidences collected were:

- a) **Sufficient** as a proof that candidate met with all requirements;
- b) **Valid** that matched the requirements of the competency standards being assessed;
- c) **Reliable** for repeatedly use in an unchanging situation to produce constant results;
- d) **Fair** irrespective of working environments, language barrier, poor instructions, special needs etc. and
- e) **Consistent** that provides different assessors to make consistent decisions about candidates' competence at different times, and on different occasions.

The moderators in QABs will conduct moderation meetings of selected assessors who were involved in those assessments and will use prescribed guidelines and check list for preparation of summary of moderation meetings findings. NAVTTTC will also organize a moderation meeting for all QABs at national level to ensure fair, valid and consistent NVQs assessment across the country

Recognition of Prior Learning (RPL)

The NVQs assessment is not limited to just the formal pathway. However, there are informal and non-formal pathways that individuals may follow for assessment for NVQs. The NVQF provides following pathways and progression for RPL entry to acquire NVQs certification at different levels (Figure 5).

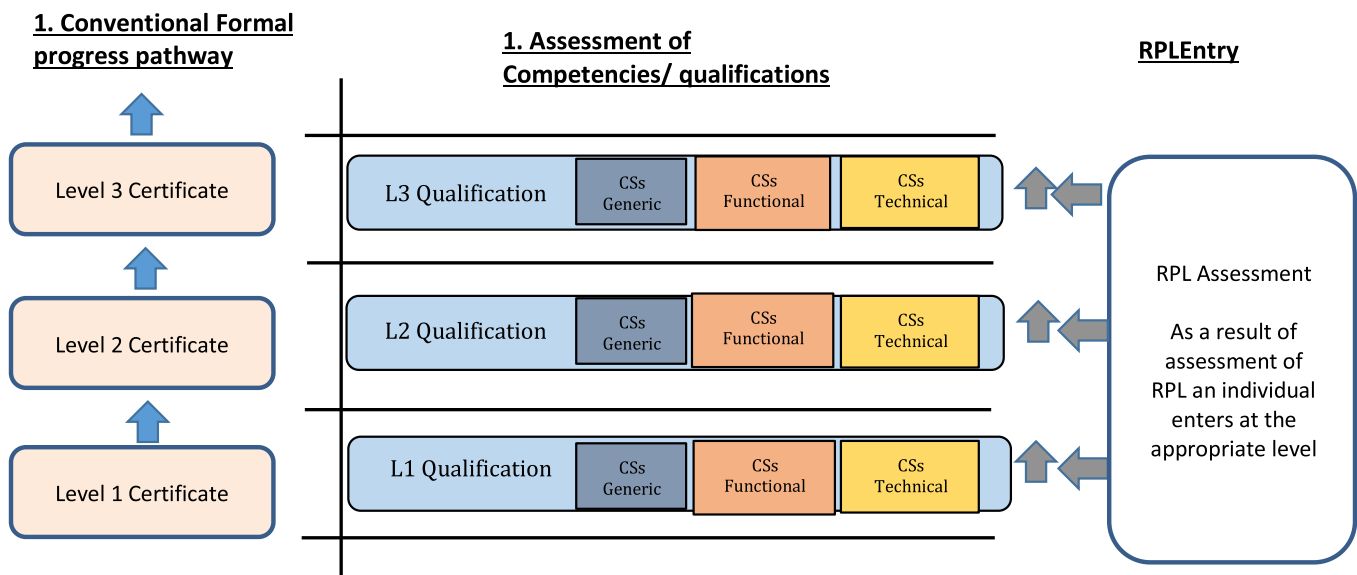

Figure 4: RPL Entry and progression in the NVQF

All NVQs will be composed of Competency Standards, which are combination of Generic, Functional and Technical.

Candidates entering through RPL system shall be assessed for their skills against those standards and may qualify for either national vocational certificate of full qualification if they are declared "Competent" or "Record of Achievement" if they are declared competent in certain numbers of competency standards.

RPL assessments will be carried out and managed by NAVTTC and the NVQF Support Units (NSUs) of TEVTAs, Qualification Awarding Bodies (QABs) and by the trained supervisors of the Assessment Centers.

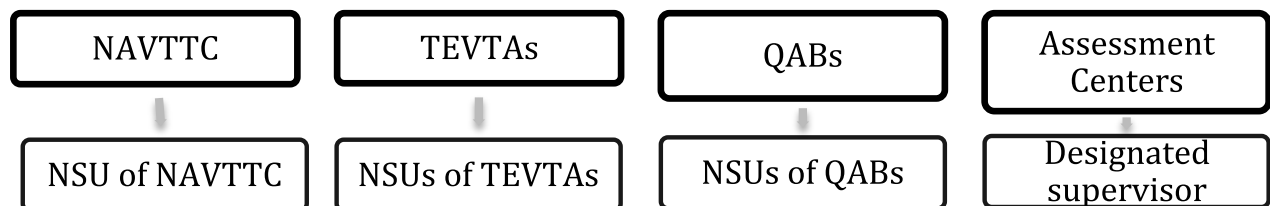

Figure 5: Management of RPL

Operational Manual-2 describes in detail the processes and associated guidelines for conducting NVQs assessment, moderation of NVQs assessment to ensure fairness, validity and consistency of assessment and recognition of prior learning for NVQs certification.

MANAGEMENT OF NVQF

The national and provincial TVET service providers will jointly manage implementation of NVQs through a well-defined structure. An “NVQF Management Committee” (NMC) at the national level will overall manage NVQF implementation and provide policy directions to ensure that NVQ level structure is appropriate, objectives are being met, management of the NVQ system is effective and efficient and employers are satisfied with the quality of NVQ graduates.

Management Structure

The NVQF will be managed through the following structure (Figure 7).

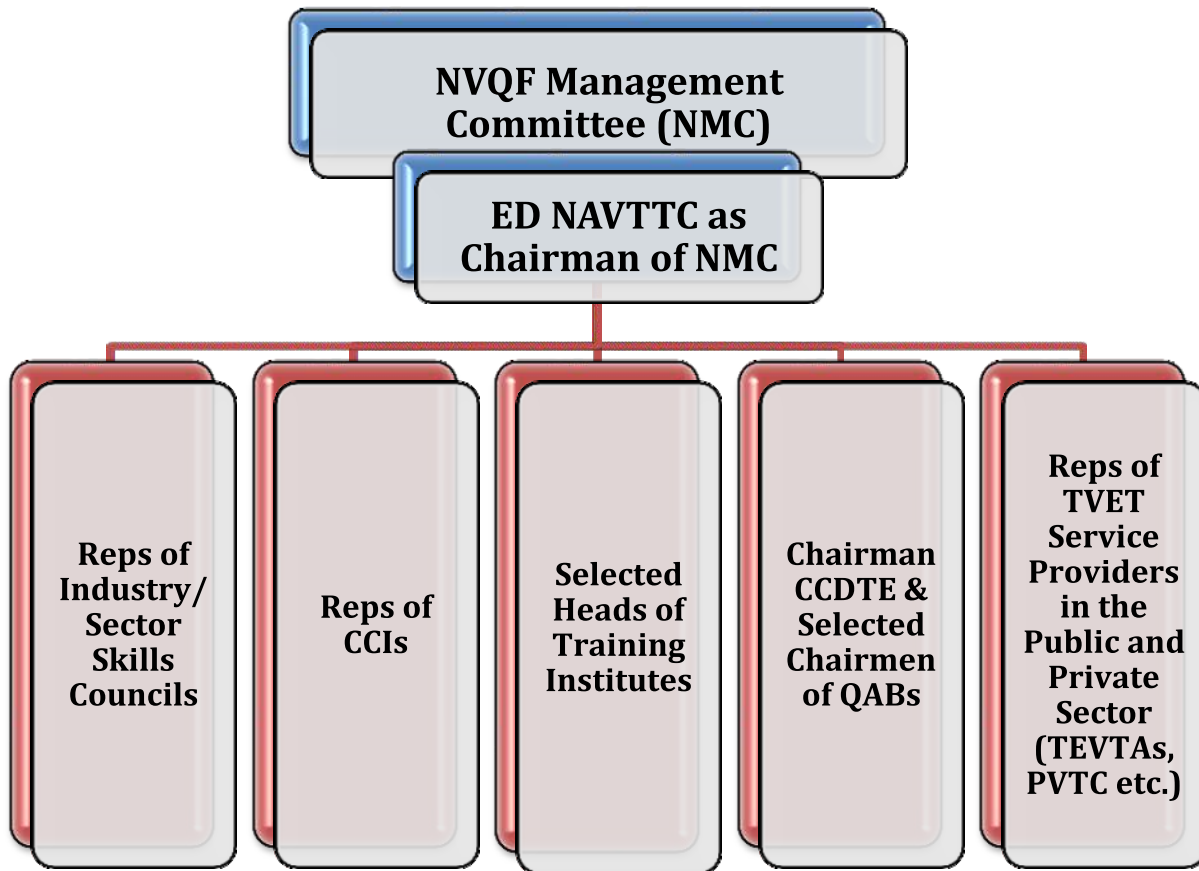

Figure 6: Management Structure of the NVQF

NAVTTTC at the national level responsible for facilitation, coordination and regulation of technical education and vocational training in the country under the NAVTTTC Act of 2011 will act as secretariat of the NVQF Management.

The composition and terms of reference of NMC have been given in the Manual-3 on “Management of NVQs”, which will be notified by NAVTTTC in consultations with all stakeholders.

The NMC will provide overall management and policy directions on management and implementation of NVQF, oversee that NVQF objectives are appropriately being met and employers are satisfied with quality of NVQs graduates, ensure efficiency, consistency and integrity of the NVQF operations as per guidelines prescribed in the operational manuals and align NVQs development and introduction as per national skill demand and trends of the international labour markets.

The NVQF management bodies i.e. NAVTTC at the national level, TEVTAs and QABs at the provincial levels, Punjab Vocational Training Council, Lahore and TVET service providers in the private sector will establish NVQF Supports Units (NSUs) to manage and coordinate implementation of national vocational qualifications in the institution under their jurisdiction. NSU of NAVTTC will coordinate with NSUs of all provincial TVET service providers (TEVTAs, QABs and Private Sector TVET bodies) and lead all activities related to management, implementation and monitoring of the NVQs.

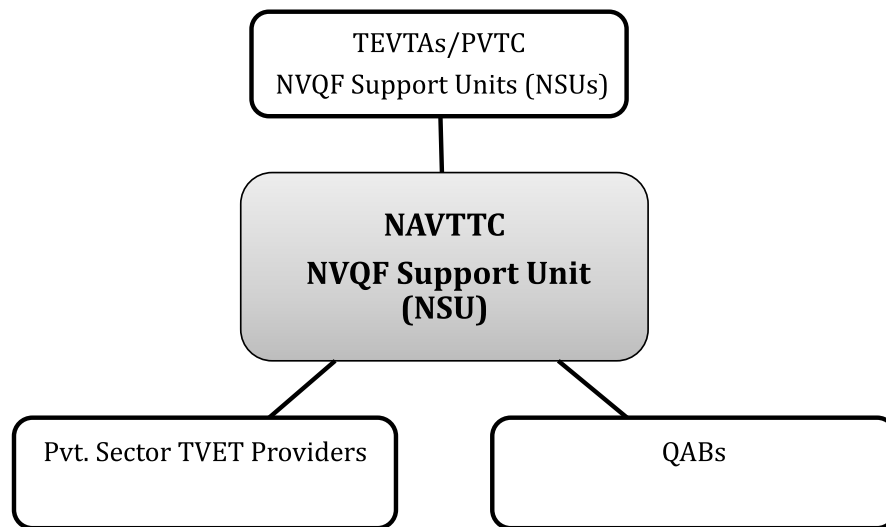

Figure 7: NVQF management bodies

Provincial TVET authorities in the public and private sector such as TVETAs and PVTC, Lahore will play an important role in management of the NVQF. While they will participate in policy discussions in NMC meetings; they also have a particular role in supplying the resources needed by the institutions introducing NVQs. Manual-3 on “Management of NVQs” describes roles and responsibilities of NSUs.

Managing NVQs Equivalences

The equivalence of national vocational qualifications will be managed for the following four Equivalence Areas.

- a)Area-1: Equivalence within the national vocational qualifications.
 - b)Area-2: Equivalences of national vocational qualifications with qualifications acquired on qualification frameworks of other countries
 - c)Area-3: Equivalence of national vocational qualifications with traditional on-going VET courses.
 - d)Area-4: Equivalence of national vocational qualifications with General and Higher Education Qualifications/ Levels.
- Considering equivalences within the NVQs (Area-1) and with qualifications acquired on qualification frameworks of other countries (Area-2) is comparatively easy to handle and start with. Granting equivalences of NVQs with existing (Traditional) vocational qualifications such as DAE, G-III, G-II and G-I (Area-3) and with general and higher education qualifications (Area-4) will evolve gradually with time at later stages.

NAVTTTC has been mandated under its Act 2011 (Clause 7 (g)) to manage and determine equivalences and recognition of diplomas, certificates awarded by the institutions within the country and abroad. The Committee of Chairmen and Directors of Technical Education (CCDTE), which already exists, will be strengthened and activated to manage, decide and grant equivalences at all the four areas mentioned above. The Inter Board Committee of Chairmen (IBCC) and HEC will be consulted for preparation of rules, criteria or table of equivalences for equating NVQs with general and higher education respectively.

Following is the structure of NVQs equivalence management by CCDTE.

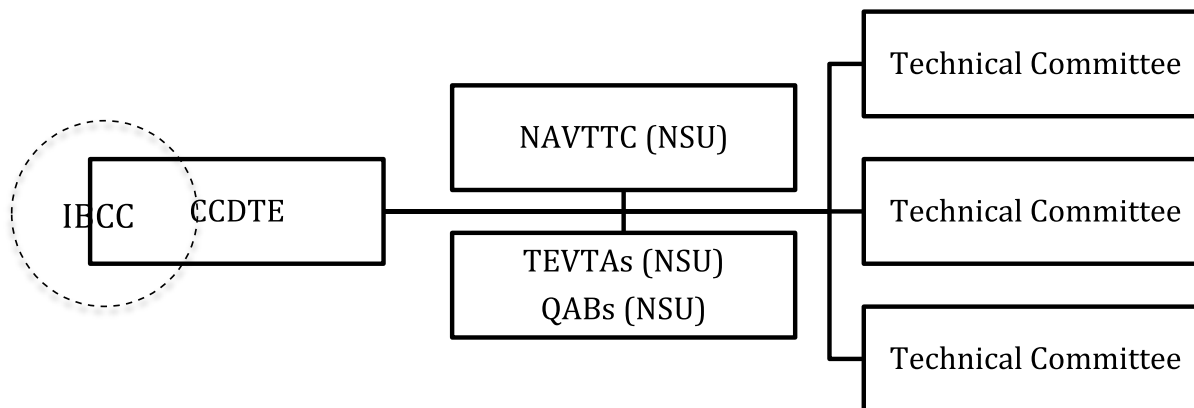

Figure 8: NVQs equivalence management by CCDTE

The CCDTE will:

- a) Prepare rules, criteria or table of equivalence for equating NVQs at all four equivalence areas mentioned above;
- b) Develop and approve all procedures for processing of equivalence applications, development of application forms and instructions for submission of applications;
- c) Grant equivalence of NVQF qualifications on all four areas mentioned above; and
- d) Coordinate among QABs and Sector Skill Councils/TEVTAs/PVTC/Private TVET service providers and with IBCC on matters related to NVQs equivalences.

Manual-3 describes procedures and processes for grant of NVQ equivalences.

Monitoring and Evaluation of NVQs

The National Skills Strategy (NSS) places importance on M&E as a way to measure progress and evaluate performance in the TVET sector. In a dedicated section, NSS defines a number of key performance indicators towards achieving the objectives of providing relevant skills for industrial and economic development. M&E will thus be a component among the five major interrelated and interconnected systems for quality assurance in the National Vocational Qualifications Framework.

Since introduction of NVQs is a major paradigm shift from the existing traditional TVET qualifications, it entails basic changes and mind-set for which an appropriate Monitoring & Evaluation system will be in-place to get feedback and accordingly take appropriate steps for adjustment and improvement.

The scope of M&E is shown in the Figure 10 below.

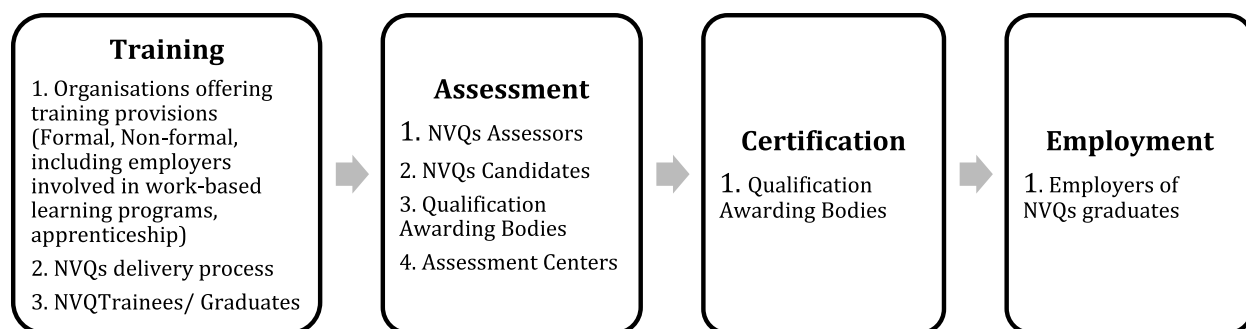

Figure 9: Scope of M&E – Collection of Feedback from Stakeholders

The major players in undertaking M&E activities will be NAVTTC at the national level and provincial TEVTAs and QABs at the provincial levels. Key indicators will be chalked out on the basis of which these bodies will devise instruments/tools to collect the data and analyse it for reporting and making decision at the level of NVQF Management Committee.

Managing NVQF Review and Improvement

To ensure that operational procedures are working efficiently and smoothly, they are effective in meeting the skill demand defined by the stakeholders and that related operations are consistent with accepted international practices, following three systematic NVQF reviews will be conducted over a 5-year cycle (Table 1):

- NVQF Operational System Review to be conducted annually
- NVQF Effectiveness Review to be conducted every 2-years
- NVQF International Review to be conducted every 5-years

Table 2: NVQF review cycle

	Year 1	Year 2	Year 3	Year 4	Year 5
NVQF Operational Review					
NVQF Effectiveness Review					
NVQF International Review					

Managing NVQ Registry

The National Vocational Qualification registry system will be designed to provide information for institutions, TVET agencies and students on the following areas;

- Overall information on national vocational qualifications (the qualification summary sheet).
- Registered assessor's pool and their profile
- Competency standards and curriculum.
- Information of students declared "Competent" with certification status.
- E-forms for requesting NVQs development or review for downloading and online submission to NAVTTC

- f) Information of QABs assessing and certifying NVQs
- g) Students registered for NVQs
- h) Status of formative assessment
- i) Schedule of integrated assessments

The National Vocational Qualifications Registry will be accessible to the following groups with different scope of access and usages.

- a) NAVTTC, provincial TVET organizations (TEVTAs, PVTC, Directorates etc.)
- b) Qualification Awarding Bodies
- c) Students
- d) TVET institutes

The National Vocational Qualification Registry System will complement the National Skill Information System, which additionally provides information on TVET system of Pakistan, TVET institutions, their existing qualifications and enrolment capacity, job placement services and labour market information system.

QUALITY ASSURANCE

The NVQF Quality Assurance (QA) system shall consist of five major interrelated and interconnected systems; 1) Quality assurance of NVQF qualifications 2) Quality assurance of the delivery and conduct of training 3) Quality assurance of assessment, 4) Quality assurance of the NVQF management system and 5) Monitoring and evaluation of the NVQF (Figure 11).

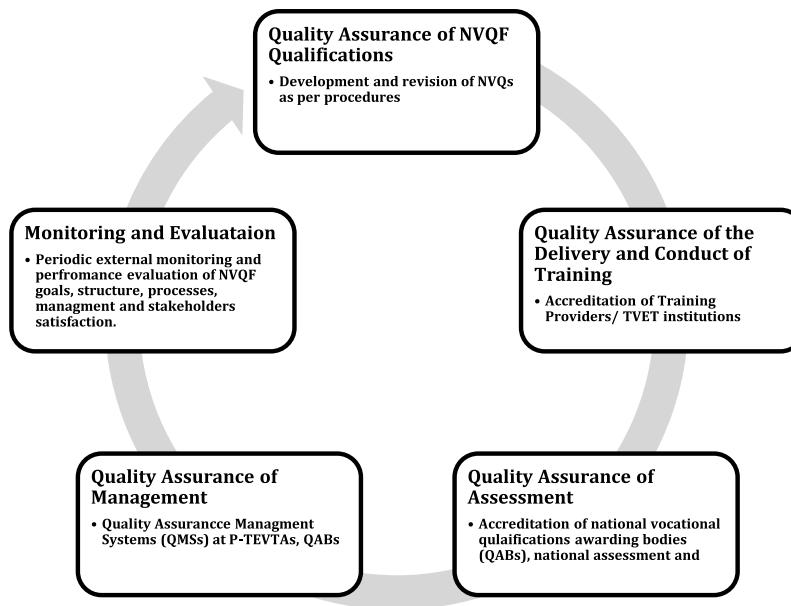

Figure 11: Five Components of the NVQF Quality Assurance System

Quality assurance of NVQF qualifications

All qualifications will be developed and/or revised through the prescribed processes as stipulated in the operational Manual-1. These processes shall ensure they meet the skill demand of the employer and that competency standards and curricula are developed with inbuilt assessment plans and finally levelled and registered on NVQF. The summary sheet will be prepared for each qualification that contains title, level, total credit, competency units and level and credit hours allocated etc. for ready reference of the stakeholders/ users. NAVTTC will coordinate and manage the development and revision of qualification in collaboration with provincial stakeholders.

Quality assurance of the delivery and conduct of training

QABs responsible for undertaking NVQs assessment will be accredited by NAVTTC in collaboration with TEVTAs. QABs will further accredit the assessment centres to ensure they have requisite infrastructure and resources to meet the assessment requirements. The maintenance of accreditation status of QABs and assessment centres will be through the periodic surveillance audit done by the team of NAVTTC and QAB's certified auditors respectively. In addition, NAVTTC will also accredit TVET institutions responsible for delivering NVQs to ensure they have proper resources and facilities in delivering NVQs. The certificate of accreditation will be withdrawn if the accredited institution fails to abide by the prescribed accreditation requirements and the minimum standards.

Quality assurance of assessment

QABs will be the major assessment and certification bodies for NVQs. The requirements for accreditation i.e. performance criteria and procedures for accreditation will be set out by NAVTTC in their accreditation manual and will be circulated to QABs. Similarly QABs will also set out performance criteria and procedures for accreditation of assessment centres. Besides, NAVTTC and QABs will ensure that a pool of trained and qualified assessors is maintained who, while assessing students, use standardized tools to document performance. All QABs will follow assessment procedures and national certification system developed mutually in consultations with NAVTTC.

Quality assurance of the management

NAVTTC, at the national level, and TVET service providers at the provincial levels are responsible bodies for management of the operation of NVQF. These bodies will require having a coherent organizational quality management system comprising policies, procedures and processes to ensure the continued relevance, appropriateness and effectiveness of the education, training and assessment services are offered. They will establish NVQF support cells manned by the professional trained staff. To ensure international comparability of NVQs, NAVTTC will join appropriate international education and training quality assurance networks and participate in the peer review processes of the international quality assurance associations through a cyclic review system.

Monitoring & Evaluation

NAVTTC, through periodic external monitoring and evaluation in collaboration with stakeholder institutions, will evaluate the performance of the NVQF and ensure that:

- a) The NVQF goals are still appropriate;
- b) The goals are being met;
- c) The structure of the NVQF is still appropriate;
- d) The quality criteria for registering qualifications, accrediting training providers and delivering assessment are still relevant;
- e) The management of the NVQF system is effective and efficient; and
- f) Employers are satisfied with the quality of the graduates with NVQF qualifications.

PROVISIONS OF FOREIGN QUALIFICATIONS IN PAKISTAN

There is a need to ensure portability and mobility of foreign qualifications in Pakistan and their equivalence with NVQs. It will not only create a healthy competitive environment with NVQs but also will contribute towards up-skilling of Pakistan NVQs.

However, organisations marketing or providing training that leads to foreign qualifications must not make claims that the foreign qualification is equivalent to any level of the NVQF or equivalent to any particular qualification on the NVQF without having had the foreign qualification reviewed by the NAVTTC against the standards of the NVQF.

The organisations that are providing foreign qualifications must provide documentary evidence to NAVTTC that:

- a. The foreign qualification is legitimately recognised under the qualifications framework of the source country, and
- b. The organisation providing training for the foreign qualification in Pakistan is actively linked to the quality assurance system of the foreign qualification. This can be either;
 - In the case of a franchised provider being under the quality assurance system of the partner organisation in the source country, or;
 - As a member or associate member of an international association of specialist TVET providers where the association has been accredited by an internationally recognised quality assurance body specialising in multi-state cross-border provision, or;
 - As a stand-alone organisation with independent accreditation through the quality assurance system of the source country

NAVTTC will assist the process through developing dialogue with qualifications authorities and bodies in key foreign countries to clarify and notify the appropriate foreign quality assurance bodies related to key international qualifications.

RELATIONSHIP WITH INTERNATIONAL NVQS

The Pakistan National Qualifications Framework, including the NVQF, has been developed on the pattern of the European Qualifications Framework (EQF) to facilitate alignment with the EQF and other key national and regional qualifications frameworks.

NAVTC, as the TVET apex body in Pakistan, is the contact point for negotiations with national and regional qualifications frameworks to establish recognition of NVQF qualifications, to establish equivalencies, and to move towards mutual recognition of qualifications. Representatives of provincial authorities and relevant industry sector groups will also participate at relevant points.

Priority will be given to establishing links with the EQF and the frameworks of key individual member states, SAARC regional framework and with the individual member countries, the qualifications frameworks of the UAE and other Middle Eastern countries.

APPENDICES

Appendix-1: NVQF Level Descriptors

Level	Descriptors			Qualification type
	Knowledge and understanding	Skills	Responsibility	
Level 1	Elementary knowledge of an area of work or study with safety procedures	Limited practical skills required to carry out single-process tasks and solve routine problems using simple rules and tools	Work or study under direct supervision with limited autonomy	National Vocational Certificate Level 1
Level 2	Basic knowledge of readily available facts, processes and general theory of an area of work or study	Basic practical skills required to complete tasks and solve problems by selecting and applying basic methods, tools, materials and information	Take responsibility for prioritising and completing tasks in work or study under indirect supervision with some autonomy and adapt own abilities when solving problems	National Vocational Certificate Level 2
Level 3	Broad theoretical knowledge and interpretation of available information in relevant contexts within an area of work or study	Broad range of well-developed mental and practical skills required to plan and complete multi-stage tasks and generate optimum solutions to specific problems in a field of work or study	Plan and manage own work and/or supervise the routine work of others, taking some responsibility for the evaluation and improvement of work or study activities	National Vocational Certificate Level 3
Level 4	Comprehensive theoretical knowledge within a field of work or study and an awareness of the boundaries of that knowledge	Comprehensive range of mental, technical and practical skills required to complete complex tasks and develop creative solutions to abstract problems	Exercise full responsibility for management and supervision in contexts of work or study activities within well-defined boundaries and where there is unpredictable change Provide inputs to review and develop performance of self and others	National Vocational Certificate Level 4
Level 5	Advanced theoretical knowledge with analytical interpretation of an area of work or study and an awareness of the boundaries of that knowledge	Specialist level of mental, technical and practical skills required to complete variable complex tasks and develop innovative solutions to abstract and complex problems in an advanced field of work or study	Carry out planning and development of courses of action with complete accountability Exercise management and supervision in work or study activities where there is unpredictable change Review and develop performance of self and others	Diploma of Associate Engineer (DAE)

1 The Pakistan National Vocational Qualifications Framework has been developed on the pattern of the European Qualifications Framework (EQF) to facilitate alignment with the EQF and other key national and regional qualifications frameworks. The eight reference levels are described in terms of learning outcomes (LOs) under "Knowledge & understanding", "Skills", and "Responsibilities". They define complexity of LOs from basic knowledge, basic skills and working under the direct supervision (level 1) to advanced knowledge, specialist technical skills and supervision & management responsibilities (level 5).

GLOSSARY

Term	NVQF Meaning
Accreditation	Procedures and processes observed to ensure that the institutes/ organizations meet minimum criteria to manage and conduct NVQ training and assessment
Assessment Evidence Guide	Guide prepared at the national level for use by the assessors for modular and integrated assessment. It consists of summary of assessment outcomes and list of tasks to be performed by the trainees
Assessment System	Procedure, processes and guidelines for undertaking NVQ assessment.
Assessment Task	A problem, a project or an activity to be performed by the individual under the prescribed competency standard
Certified Assessors	Assessors who qualified Level-4 qualification, which has been developed, approved and notified by NAVTTC.
Competency Standards/ Competency Standard Package	A statement specifying the required performance to a defined standard at the work place. It is determined by industry and specifies the performance required to be able to work effectively. In DACUM table, these are the major "Duties". They are further divided in to "Generic", functional" and "Technical".
Competency Units	A sub-component of the competency standard containing the group of related competent performances to perform a particular function or task in a particular job or occupation.
Competent	An individual who have been declared successful through an integrated assessment organized by QABs and qualify for NVQ certificate
Consistent Assessment	An assessment based on evidences that provide different assessors to make consistent decisions about candidates' competence at different times, and on different occasions
Credit hours	A measure of the volume or amount of learning time needed to achieve the competency. In the NVQF, one credit is equivalent to 10 hours of learning.
Curriculum	A systematic plan, based on the competency standards and competency units that sequence learning and assessment activities to enable trainees to gain the competencies required to achieve the qualification.
DACUM (Developing A Curriculum)	A method of analysing jobs and occupations that results in the production of a chart listing the duties, tasks, and related information about the job. The chart provides a basis for developing competency standards and competency units
Equivalence	Refers to equivalence between and within the qualifications which allows learners to accelerate the acquisition of qualifications within the same qualifications framework or can be used in facilitating international cross recognition.
Fair Assessment	Assessment based on evidences gathered fairly irrespective of working environments, language barrier, poor instructions, special needs etc.
Formal Pathway	Learning or achievement acquired by an individual through a structured curriculum, which was offered in a formal technical and vocational institute
Formative Assessment	Assessment performed by the trainer after teaching each module of the TLM or competency standard.
Generic skills	Competencies common to industry sectors and often form the core of several related qualifications. It includes, communication skills, teamwork skills, interpersonal skills, lifelong learning skills, ability to apply skills etc.
Horizontal Progression	Refers to horizontal progression of individual to acquire further education in the same level qualifications
Informal Pathway	Learning or achievement acquired by an individual through work place/

	labour market experience or traditionally called “Ustad-Shagird” system
Knowledge and Understanding	Component of the competency standard and a NVQF level descriptor that describe what an individual knows and understands (the body of facts, principles, theories, practices) related to the particular qualification at that level.
Learning Elements	Learning elements are derived from “knowledge and understanding” part of the competency standards which reflect the underpinning knowledge required to achieve the learning units specified in the curriculum
Learning Outcomes	A unique statement that describes knowledge, skills/competencies and responsibility an individual has acquired and/or is able to demonstrate after completion of a learning process, either through formal or non-formal/informal means.
Learning Units	A sub-component of a Module describing a specific grouping of learning outcomes relating to one or more related competencies
Lesson Plan	A plan prepared by the trainer to teach complete modules with detail of teaching and learning activities to be conducted, methodologies to be used and undertaking formative assessment to ensure learning has taken place.
Levels (NVQF Levels)	Levels means NVQF level structures which starts with level 1 qualification (semi-skilled worker) and successively progress up to level 8.
Lead Assessors	Assessors who qualify Level-5 qualification, which has been developed, approved and notified by NAVTTC. They are to be used as trainers of level-4 certified assessors
Moderation Checklist	Checklist that provides areas and indicators to ensure that the assessment made was valid, reliable and consistent and that the correct processes were followed to arrive at the assessment outcome.
Moderation Summary	Summary of moderation meeting outcomes for future reference and use by the assessors and QABs
Moderation System	A system that provides a mechanism to judge and ensure that the assessment made is valid, reliable and consistent across the country
Module	A sub-component of the curriculum that defines a sequence of related learning experiences related to one or more Competency Units. They are derived from the Competency Standards.
Monitoring and evaluation system	System that provides processes and guidelines for undertaking NVQF monitoring and evaluation for efficient and smooth management and implementation at national and provincial levels
National Management System	System/ structure of management of NVQF at national and provincial levels to ensure quality
National Skill Information System	System that provides information about the whole TVET system encompassing TVET qualifications, institutions offering TVET qualifications, enrolment, instructors, facilities, pass outs, employment opportunities, job placement etc.
National Vocational Qualifications	Qualifications approved and notified at the national level by NAVTTC and are registered under the National Vocational Qualification Framework
Not-yet-Competent	An individual who have not been declared successful through an integrated assessment organized by QABs and didn't qualify for NVQ certificate
NVQF Equivalence System	System of providing a framework, processes and guidelines for granting equivalence of NVQ at the four prescribed levels
NVQF operational system	System that contains manuals with guidelines and processes for management of NVQF, Development of NVQs and assessments of NVQs
Non-formal Pathway	Learning or achievement acquired by an individual through an un-structured curriculum, which was offered at work place or enterprise that didn't lead to an officially accredited qualification
NVQ Registry	System of maintaining and updating information about NVQs,

	Management Bodies at the national and provincial levels, NVQs assessment and assessor information and students graduated with NVQs
Monitoring & Evaluation system	System that provides processes, guidelines and indicators for undertaking NVQF monitoring and evaluation for efficient and smooth management and implementation at national and provincial levels
Organizational Management System	System that shows national and provincial organizations involved in management of NVQF and their role and responsibilities in managing the development and assessment of NVQs
NVQF Level Descriptors	A statement that describes the main learning outcome under “Knowledge & understanding”, “skills”, and “responsibility” relevant to the qualification at that particular level.
NVQF Level	Level describes the pathway for horizontal and vertical progression under a set of descriptors that indicate the complexity of the skills and knowledge that the learner will have achieved.
Pathway	Indicate path to the students to move through qualification levels with full or partial recognition for the qualifications and/ or learning outcomes they already have.
Performance Criteria	Component of competency standard and NVQF level descriptor which specify the critical evidence for the purpose of assessment to ascertain that the individual has acquired and is able to do, to meet the requirement of particular competency unit.
Portfolios	Documentary evidences such as certificates of trainings, reference letters, projects/ products, photos, videos as proof of acquired skills for NVQ certification
Quality Assurance Management System or Quality Management System	One of the Quality management component to assure NVQF is managed through well-planned procedures and processes consistent with international standards
Qualification Awarding Bodies	Bodies which are responsible for assessment and certification of NVQs as mandated under their Act/Functions
Qualification Summary Sheet (Qsheet)	A summary of qualification that describe the title, level, total credit hours, competency standards with level and credit hours and other necessary information in a standardized format as a quick reference for all stakeholders.
Qualification Registration	Refers to registration of Qualification on NVQF to make it credible and acceptable within the employment market with the backing of both the relevant industry and Government of Pakistan.
Recognition of Prior Learning (RPL)	Process of recognition of already gained skills of the individuals (with or without portfolios) to enable them to acquire NVQ after going through NVQ assessment system
Reliable Assessment	Assessment based on evidences that can be used repeatedly in an unchanging situation to produce constant results
Technical Committees	Committee constituted by NAVTTC on case-to-case basis to finalize findings and recommendations on equivalences cases for submission in CCQAB meeting for final decisions
TLM	Teaching and Learning Materials. A package of materials that support the teaching programme and the learning activities that are aimed at helping the learner achieve the competencies. It includes trainer and learner’s guides
TVET Service Providers	National and provincial TVET bodies in the public and private sector that are responsible for management, development and assessment of NVQs. They include NAVTTC, provincial TEVTAs, QABs in the public sector and bodies like PVTTC, SDC, SSC and other private sector institutions providing NVQs across the country
Valid Assessment	Assessment based on evidences that match the requirements of the competency standards being assessed

National Vocational & Technical Training Commission (NAVTTTC)
5th Floor, Evacuee Trust Complex, Sector F-5/1, Islamabad
Tel: +92 51 904404, Fax: +92 51 904404, Email: info@navttc.org
Website: www.navttc.org